

### PIEDI IN PA6 GF30

PA6 GF30 FEET / PIEDS EN PA6 FV30

Piede indipendente realizzato in PA6 FV30 per innesto rapido di profili 41x41 mm e 40x40 mm con foro di fissaggio per ancoraggio al suolo e fornito di serie con tappeto antivibrante in gomma SBR riciclata. Dotato di foro centrale e canali di scolo acqua. Portata singolo piede 600kg. testata con peso statico superiore 2,5 volte.

#### [EN]

Independent foot made of PA6 GF30 for a quick insertion of both 41x41 mm and 40x40 mm struts with holes for fasteners (not included) to secure the foot to the floor, supplied with anti-vibrations rubber mat. Provided with central hole and drain slots on the underside of the mat. 600 kg load for single foot, tested with static weight 2,5 times higher.

#### [FR]

Pied indépendant réalisé en PA6 FV30 par greffe rapide et pour profils 41x41mm et 40x40mm avec trous pour la fixation au sol et fourni de série avec plaque antivibratoire en SBR recyclé. Drainage pour l'eau et trou central de série. Charge 600 kg. par pied testée avec un poids statique 2,5 fois supérieure.



| <b>T-610-1</b> |   |                   |                   |                               |      |          |  |
|----------------|---|-------------------|-------------------|-------------------------------|------|----------|--|
|                | kit con 2 piedi, 2 tappeti antivibranti, 2 spinotti regolabili e viteria di fissaggio / kit with 2 feet, 2 antivibration mats, 2 adjustable legs and fixings / kit composé par 2 pieds, 2 plaques anti-vibrations et 2 jambes réglables avec visserie |                   |                   |                               |      |          |  |
|                | √   | 300 mm<br>12 inch | 300 mm<br>12 inch | 228/353 mm<br>8.98/13.90 inch | 2 pz | € 168,00 |  |

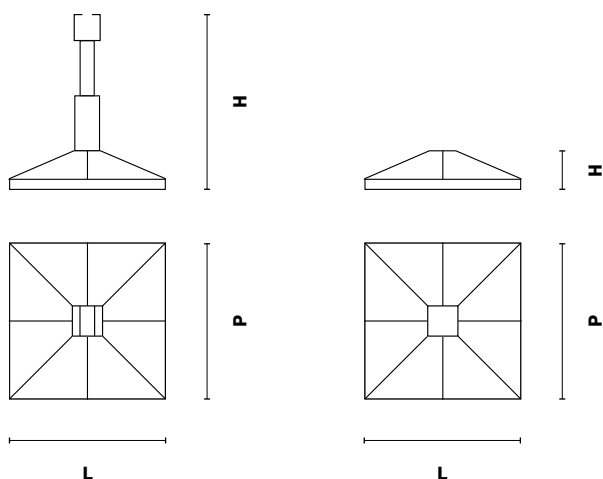

| <b>T-711</b> |  |                   |                   |                    |              |          |  |
|--------------|--|-------------------|-------------------|--------------------|--------------|----------|--|
|              | kit 2 piedi con tappeti antivibranti / kit 2 feet with antivibration mats / Kit composé par 2 pieds avec plaques antivibratoires |                   |                   |                    |              |          |  |
|              | √  | 300 mm<br>12 inch | 300 mm<br>12 inch | 85 mm<br>3.35 inch | 2 pz (1 kit) | € 71,06* |  |

\* Prezzo al kit / Price per kit / Prix par kit